

TIMX-W190

19 Inch Marine Monitor

GENERAL _

This specification defines the descriptions for the TIMX-W190 TFT LCD Monitor. TIMX series is developed and designed for use in operator display such as Industrial and Marine applications.

KEY FEATURES _

- 19.0 Inch display, 5:4 / 1280 x 1024 Resolution
- DVI, RGB, HDMI input
- Full Range Digital Dimming Control
- Picture in Picture (PIP)
- Capacitive touch OSD Control
- Optional Power Supplies (AC or DC)
- Resistive Touch Screen
- VESA, Flush, Stand Mounting

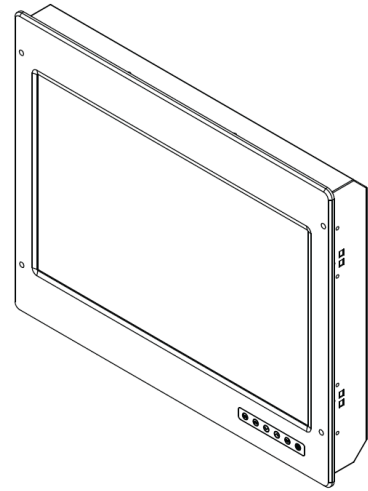

TIMX-W190

GENERAL FEATURE _

Section	Specifications
TFT Technology	Active Matrix Liquid Crystal Display
	Amorphous TFT (Thin Film Transistor)
	Anti-Reflective
	LED Backlight Technology
Viewable Size	19 inch diagonal
Active Area	376.32mm (H) x 301.06mm (V)
Resolution	1280 x 1024
Pixel Pitch	0.294 (H) x 0.294 (V)
Aspect Ratio	5:4
Response Time	5ms
Brightness	250cd/m ²
Contrast Ratio	1000:1
Viewable Angle	89°/89°/80°/80° (Right/Left/Up/Down)
Max Colors	16.7Million True Color
Synchronization Range	31~80KHz (Horizontal)
	55~76Hz (Vertical)
Detectable Resolution	640 x 480, 800 x 600, 1024 x 768, 1280 x 1024
Input Signal	1 x DVI, 1 x RGB, 1 x HDMI
Power Specification	100~230VAC 50/60Hz (IEC Standard Type) or DC24V (Terminal Block)
Power Consumption	35W (MAX)
Product Dimension	483mm (W) x 70mm (D) x 399mm (H)
Weight	8.7kg
Operation Conditions	Temperature : -15℃ to +55℃ / Humidity : up to 95%
Storage Conditions	Temperature : -20℃ to +60℃ / Humidity : up to 95%
Options	Resistive Touch Screen
	Anti Glare Glass
Test Approval	IEC 60945 4th, IACS E-10, IEC 60529
IP-Rating	IP65 Front
Certification	DNV

19" Marine Monitor

•TIMX-W190

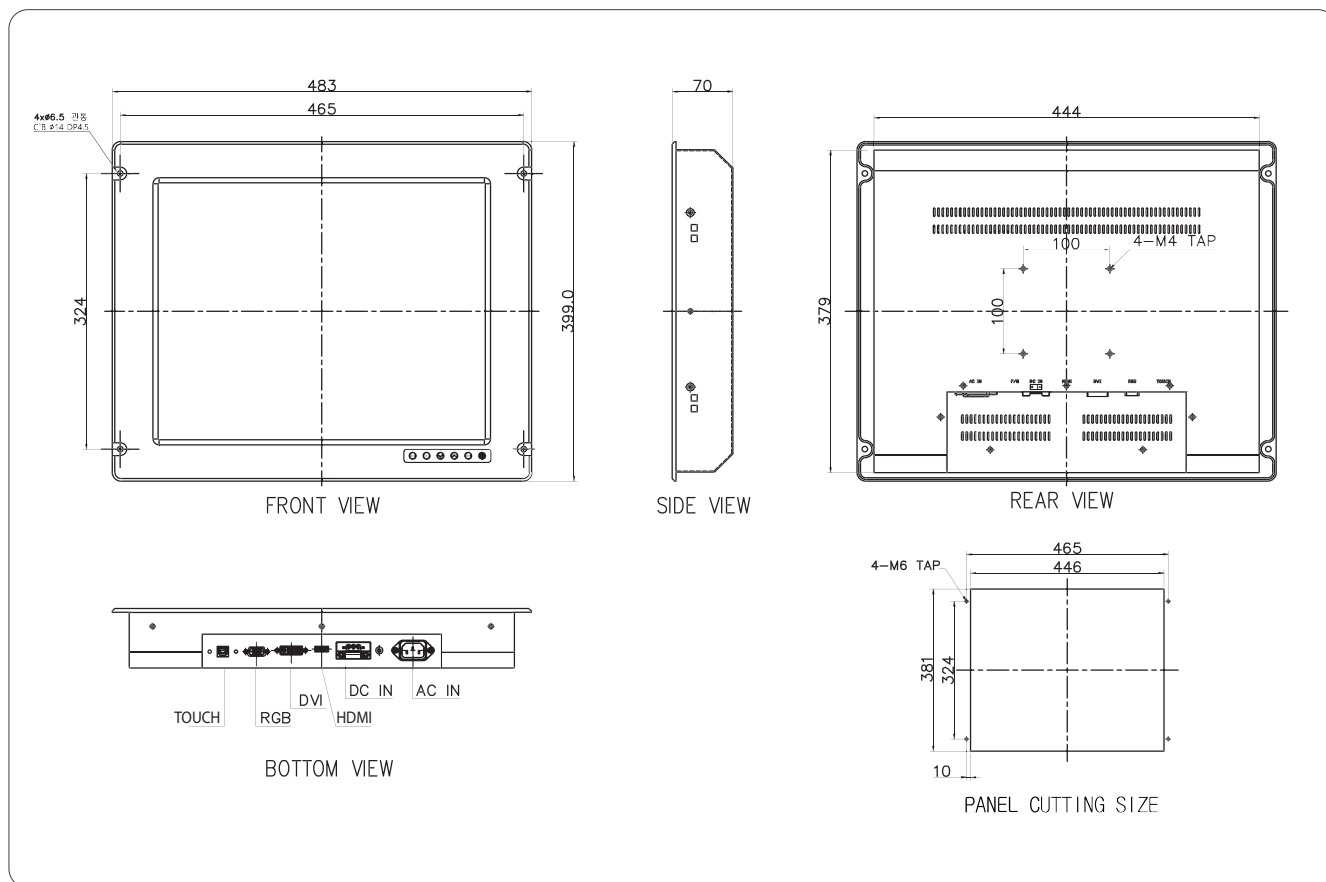

Headquarters: #604/605, E&C VENTURE DREAM TOWER II, 55, DIGITAL-RO 33-GIL, GURO-GU, SEOUL, 08376, REP KOREA

Tel : +82-2-323-4972, E-mail : sales@tetradyne.co.kr Web site : www.tetradyne.co.kr

Busan Office: 112-215, 41, Yutongdanji 1-ro, Gangseo-gu, Busan, 46721 Korea

Tel : +82-51-796-3972, E-mail : sales@tetradyne.co.kr

Specifications and features are subject to change without notice.

All products names are trademarks or registered trademarks of Tetradyne.co.,Ltd.